

How To Build A Federation Garden Pavilion

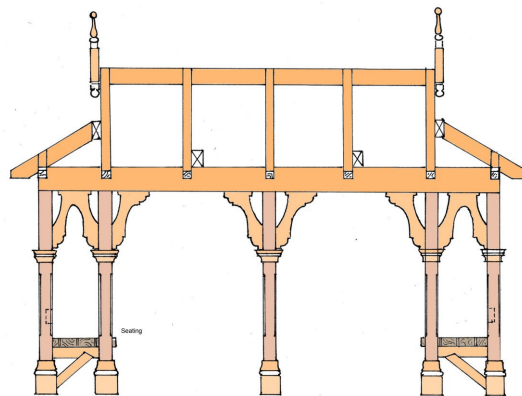

*****Safety First*****

Please read the section on workplace safety at the end of this manual before proceeding with any work.

How To Build A Federation Garden Pavilion

Garden Pavilions can be built to many different shapes and sizes and can be constructed from many different materials. Whatever the design, or the materials used for its construction, pavilions are basically constructed using the same methods.

For the purpose of this manual we explain how to build a garden pavilion constructed from treated pine. Treated Pine can be ordered raw or dressed (smooth) and primed.

Roof claddings are not the subject of this manual, however there are several choices depending on the slope and size of the structure. Generally lightweight iron or clear roof sheets are used. If you are intending to use a substantially heavier cladding material, (such as tiles or slate), then the structure will have to be strong enough to carry the load. Where roof claddings are used, stormwater runoff will have to be considered. A suitable gutter and downpipe system should also be installed.

Construction

The size of the garden pavilion we are constructing measures up to 5.4 metres long by 3.0 metres wide. It is being installed at a height of 2550mm to the underside of the beams. These measurements can be altered to suit your area. If increasing the size of the structure, or spacing between the posts refer to the span tables for suitable timber sizes.

Materials required;

Timber

Treated Pine can be ordered raw or primed ready for painting. You must specify which type you require at the time of ordering.

Posts	10 @ 3.6m	90 x 90mm (or 115 x 115) treated pine
Beams	2 @ 5.4, 2 @ 3.0	190 x 45mm treated pine
Rafters	10 @ 2.4m, 8 @ 1.8m	90 x 45mm treated pine
Roof Battens	14 @ 4.2m	45 x 45mm treated pine
Ridge Beam	1 @ 4.2m	190 x 18mm treated pine
Collar Ties	2 @ 3.0m	90 x 45mm treated pine

Timber for brackets or collars must be added separately.

If you are increasing the size of the pavilion refer to the span tables for timber sizing.

Hardware

20 cuphead bolts 110mm x 10mm galvanised plus 8 nuts and 8 washers
10, 20kg bags of concrete mix
2 tubes of waterproof glue (liquid nails or similar)
500g pack 100mm x 6mm galvanised screws

Step 1

Setting Out.

Clear the work area of all plants and vegetation and roughly level the ground.

Mark out the perimeter of the proposed garden pavilion with a string line and some timber profiles. The rafters have an overhang of 250mm on each end.

Set out the post holes at according to the size of the structure required and the overhang of the rafters.

Step 2

Excavation.

This garden pavilion has 10 posts as shown, therefore 10 holes will need to be dug for the posts. These holes should measure 300mm x 300mm wide by 450mm deep per post. Make sure the bottom of the footings are cut square and not rounded, see Fig 2.

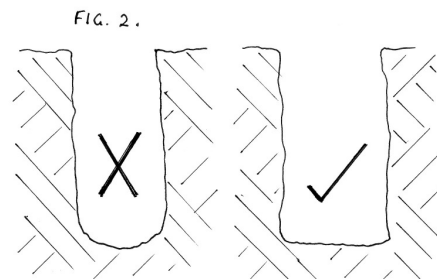

The Pavilion measures 5.4m long by 3.0m wide, (plus the roof overhang). Set out a rectangle 5.4m long by 3.m wide using string lines, in the position required. The corners of the string line mark the outside of the corner posts.

The side posts are not evenly spaced. The pavilion seats on either end of the structure are supported by the two end posts on either side. The centre post is in the middle of the beam.

Space the end posts so that there is a gap of 400mm between them. This will allow fixing points for the bench seats.

Step 3

Cut the Posts.

Place the posts side by side on a pair of saw stools, even up one end and clamp them together.

Using a square mark a line across the end of the four posts. Measure down 190mm

And mark another line. With the posts clamped together use a power saw set to 40mm deep and cut a row of parallel lines (around 20mm apart).

Remove the excess with a sharp chisel as shown in Fig 3.

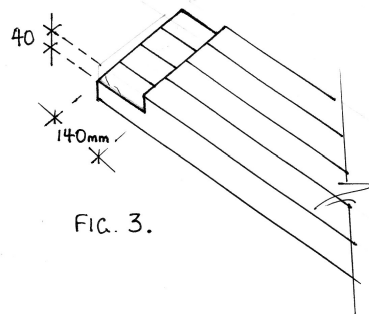

Using a 10mm drillbit, drill two evenly spaced holes through the end of the posts as shown Fig 4. This is for the bolt holes to attach the beams.

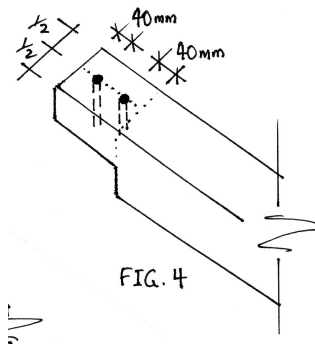

A chamfer or routed moulding can be formed on the posts. This should start 600mm from the bottom of the posts and end 500mm from the top. If you are intending to build a high pavilion, a timber freize can be added to the underside of the beams. If this is the case the chamfer can start lower down, (see pic below)



These measurements can be adjusted to suit your requirements.

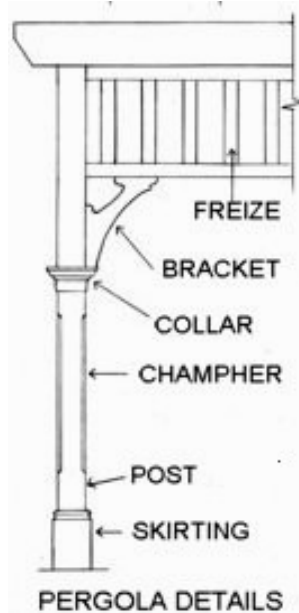

A Federation style collar or skirtings can be added to the posts for decorative effect. See below for collar examples.

Step 4.

Cut the beams.

The first step is to cut the four beams. There is no overhang on the beams. The ends of the beams must be cut with a 45 degree angle to meet at the corner posts.

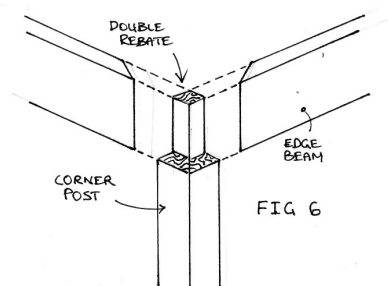

Timber has a natural curve or bend, not only to the side but also up and down. When cutting the beams and rafters, ensure that the natural curve is facing up.

Step 5.

Cut the Rafters.

Once the pitch of the roof has been calculated, draw up a scale picture of the roof on the ground or a large flat surface. We suggest a pitch of 33 degrees for federation styled roofing.

Draw a line 3m long (this is the width from outside of beam to outside of beam). This line represents the top of the beams. Draw a perpendicular line up from the centre. Cut a 33 degree angle on the end of two rafters and place them with the bottom edge touching the line at either end and the 33 degree angle meeting neatly on the centre line.

The rafters are butted into the ridge beam at the top of the roof and require a birdsmouth (rebate) over the edge beams. Use an offcut of the ridge beam (190mm x

18mm) and place it between the tops of the rafters, centred on the line. The top of the ridge beam should be flush with the top of the rafters.

Now you can mark the birdsmouths. Using a ruler and pencil first mark the vertical outside edge of the beam across the rafter. The birdsmouth should be cut to one third of the width of the rafter. Mark a 90 degree angle (parallel to the top of the beam) one third of the way up the vertical line to form a triangle of timber to be removed from the rafter. This is the birdsmouth.

The rafters are to fix to the ridge beam at the top of the roof and are nailed through the birdsmouth into the top of the beam. Rafters are placed adjacent to each other, and are spaced at a maximum of 450mm apart.

The roof design for the pavilion demands that the end pairs of rafters start 750mm from the ends of the beams. This is to allow for the end roof(s).

Cut two rafters first and try them out on the roof. Tack them in position and stand back to assess the look. If a steeper pitch is required, new rafters will have to be cut, so check the pitch suits your expected look before continuing.

If you are happy with the template rafter, mark out the other long rafters and cut them all to the same size.

Step 6.

Assemble the roof.

Place two rafters opposite each other and temporarily nail to the beam. Leave the top ends of the rafters leaning together but not nailed yet. Repeat this with another set of rafters, then slide the ridge beam up between the rafters, so that the rafters meet flush with the top of the ridge beam. The rafters will hold the ridge beam in position until you can nail it.

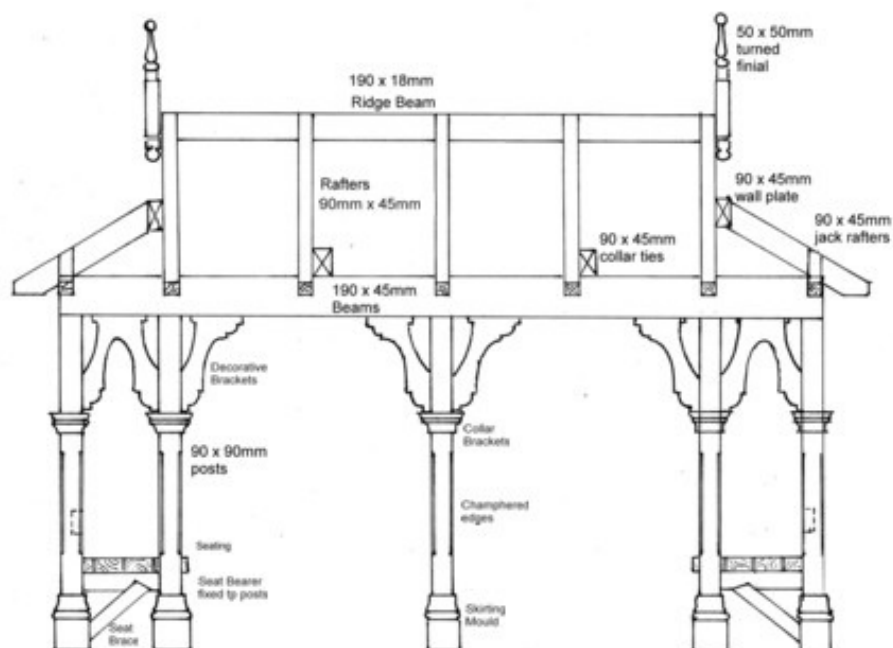

The rafter spacings can be set out on the beam and the ridge and the remaining long rafters fitted and nailed. Two braces are required at a 45 degree angle across the top of

the rafters to keep the roof square and straight. Hoopiron or speedbrace is commonly used. A temporary brace may be required during assembly.

Step 5.

End Rafters.

First a plate will need to be fixed to the edge of the existing rafters. This is to nail the top of the small end rafters to. The plate can be made from 175mm x 25mm treated pine.

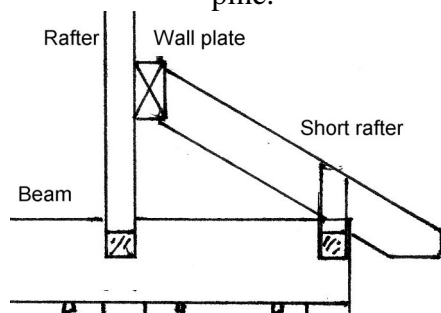

A small hip rafter is cut to sit on 45 degrees to the rafters, and is to be birdsmouthed to the same height as the rafters. Nail these hips to the wall plate and rafter.

The shortest rafters that run off the hip have a plumb cut with a side angle of 45 degrees.

A Fascia board 140 x 18mm can be fixed to the side top of the rafters as shown (above the lower roof). A turned finial can be skew nailed over the join of the fascia boards.

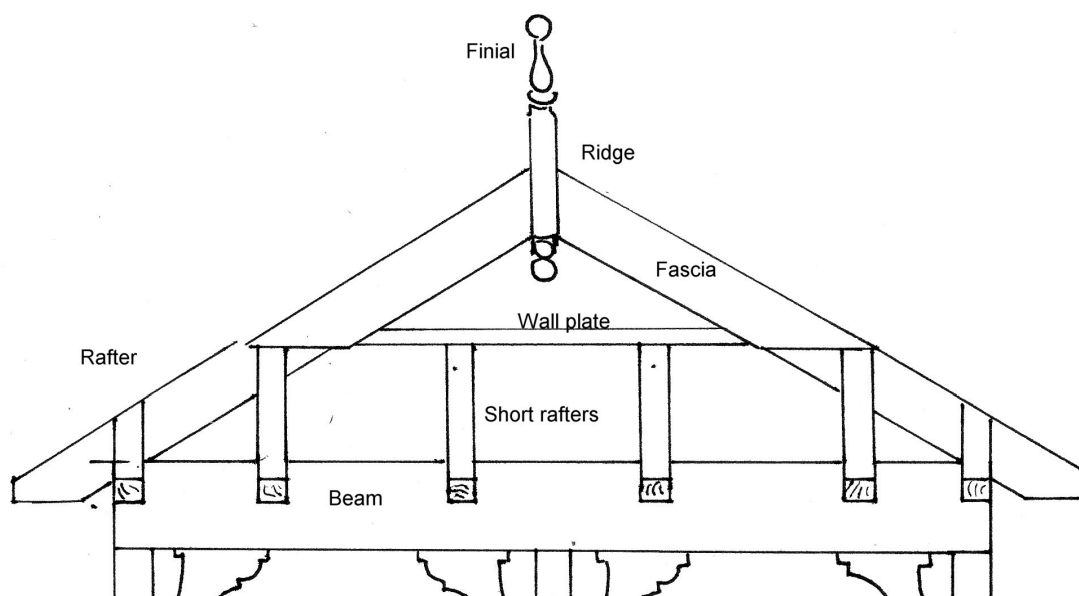

Measure the small rafters using the method described in step 4, including the same birdsmouth, and angle at the top (plumb cut). Install the rafters starting with one on either end of the plate and position flush with the top of the longer rafters. These can be skew nailed into the plate.

Step 6.

Hip rafters

The hip rafters are the short rafters that do not meet the plate or ridge beam. These are located in the corners of the roof. To make the hip rafters a hip plate must first be made. The hip plate is constructed from 150mm x 20mm treated pine and is cut to run on a 45 degree angle from the corners of the beam up to the end of the plate that holds the short rafters. This bevel will be different to the bevel used for the end cut on the rafters.

Four pairs of short rafters will have to be made and fitted to the corners of the roof. Mark one and try for size before cutting the rest.

Step 7.

Decorative timber work

For bracing, cut 20 timber angle brackets and fix with galvanised nails and waterproof glue. The finials and post collars can also be fitted.

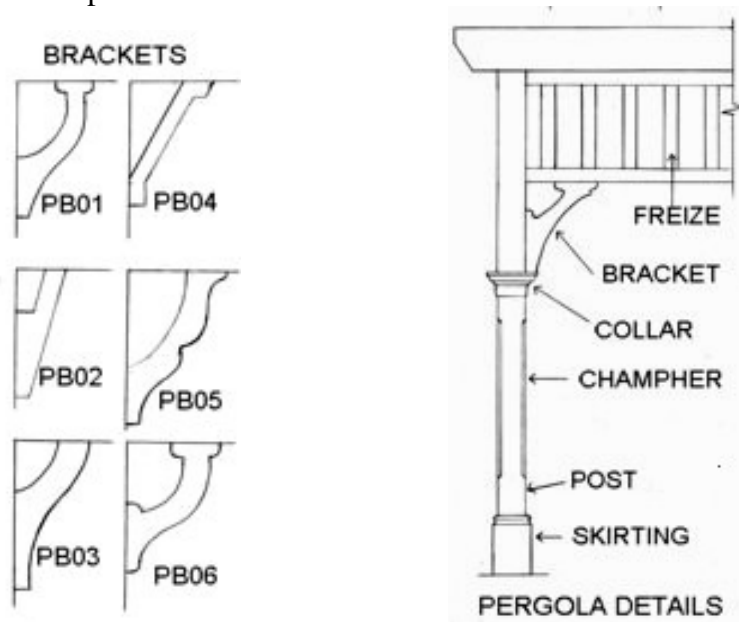

A timber freize and post skirtings can also be added for decorative effect.

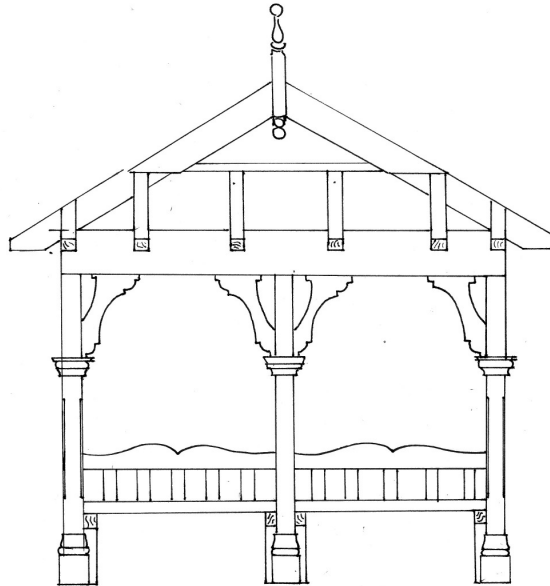

Step 8

Fix the seating. The seating for the pavilion is situated at both ends and is constructed from 90mm x 45mm treated pine. First the bearers have to be bolted to the posts. Using 100mm x 10mm galvanised coach screws, bolt the bearers to the posts. A 45 degree brace is used for the centre posts, to support the bearer.

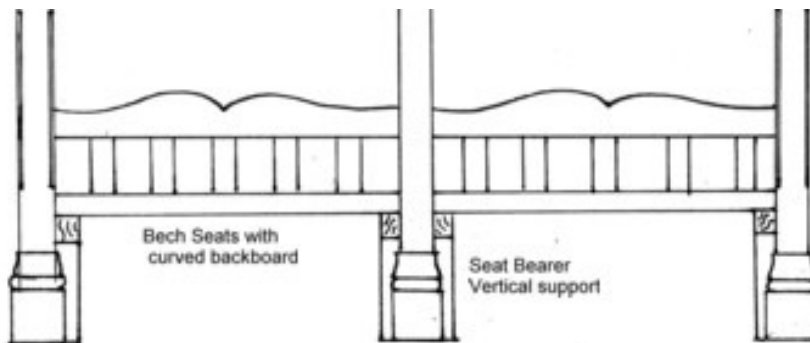

The backboard is cut using a jigsaw to any shape you prefer. Pictured is the standard moulding seen on these pavilions. Pickets are then cut and dowelled between the curved topboard and the bottom seat.

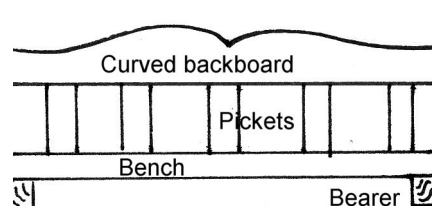

The seating can be fixed to one or both sides of the pavilion.

Finally, sand and putty and prepare for painting.

Happy Building!!!